

Item	Qty	Title	Part Number
1	1	Base Plate	TBB_FPF_01
2	2	Die Post	TBB_FPF_02
3	2	Tower Gusset Left and Right	TBB_FPF_03
4	1	Top Plate	TBB_FPF_04
5	1	Pin Plate Weldment	TBB_FA_05
6	1	Tower Stop Plate	TBB_FPF_09
7	1	Tower Push Plate	TBB_FPF_16
8	1	Plate Extension	TBB_FPF_20

B

↕

A

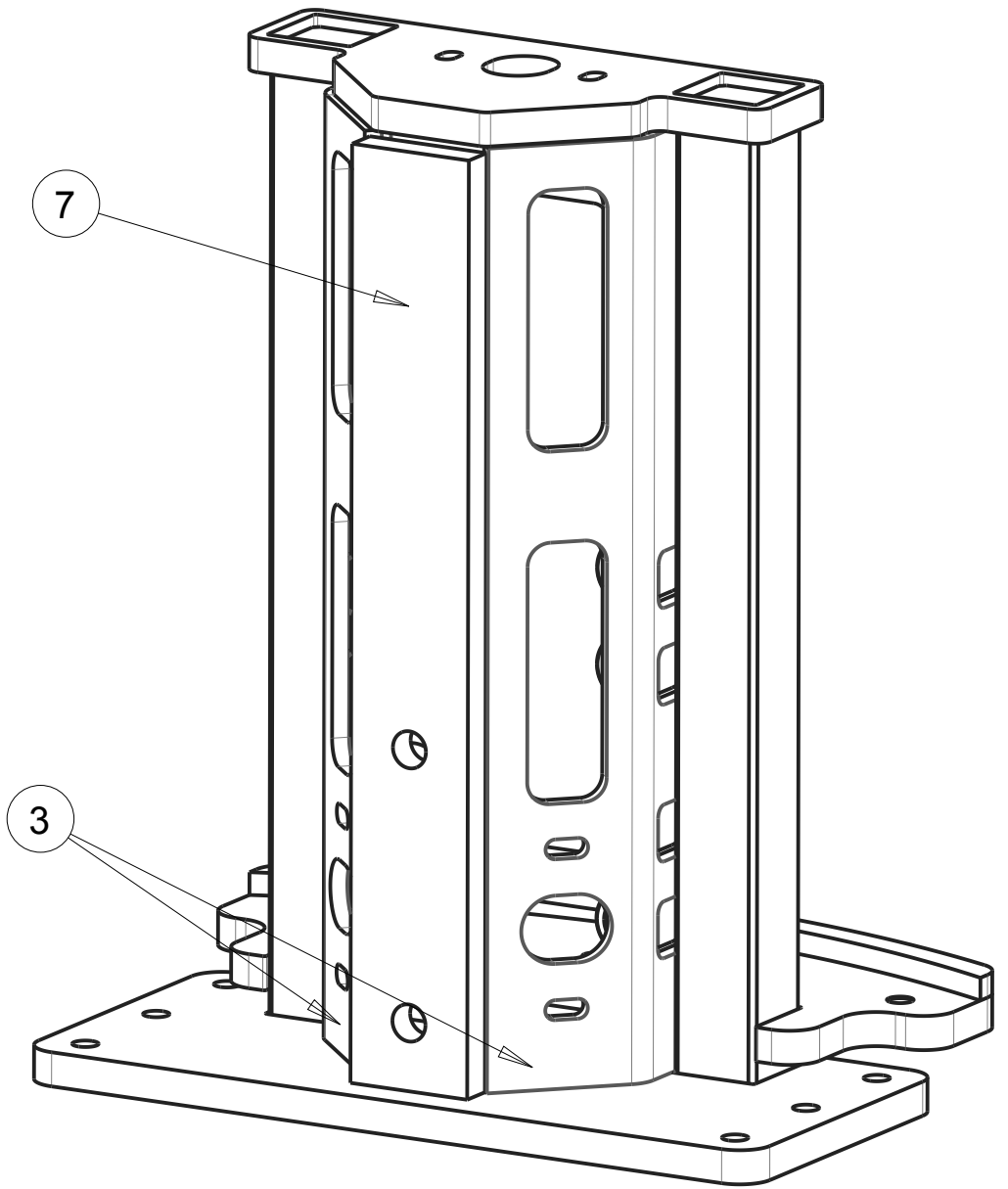
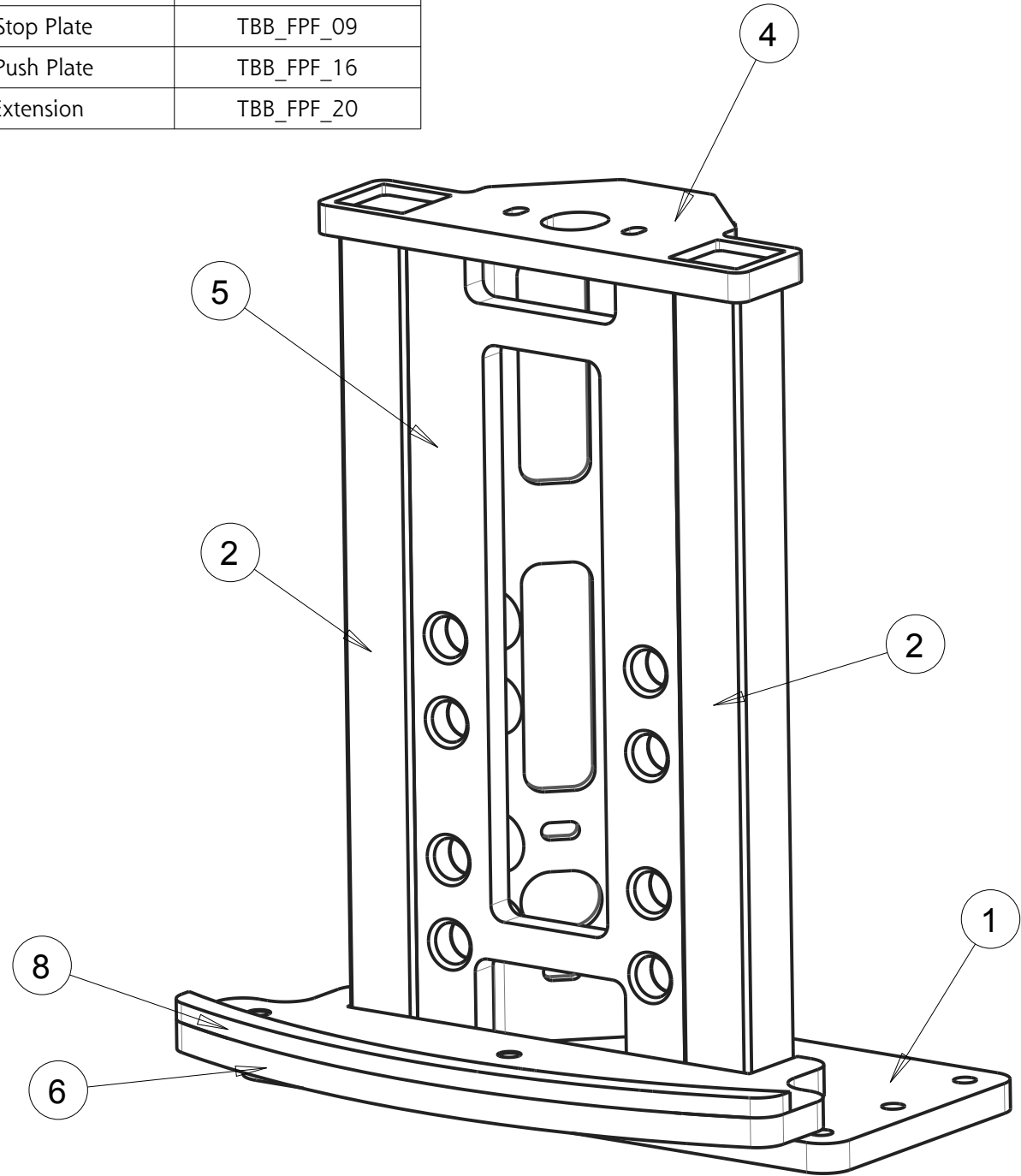

Your LOGO Your Company Name Address Phone Number	ENGINEER AHA	DATE 11/24/12	CONFIDENTIAL INFORMATION	
	DESIGNER AHA	DATE 11/24/12	TITLE Tower Weldment	
	DRAWN AHA	DATE 11/24/12	B	DWG. NO TBB_FA_01
	CHECKED AHA	DATE 11/24/12		REV 1
THIRD ANGLE PROJECTION 		SCALE: 0.111	SHEET 1 OF 2	

4

3

↑

2

1

TBB_FA_01

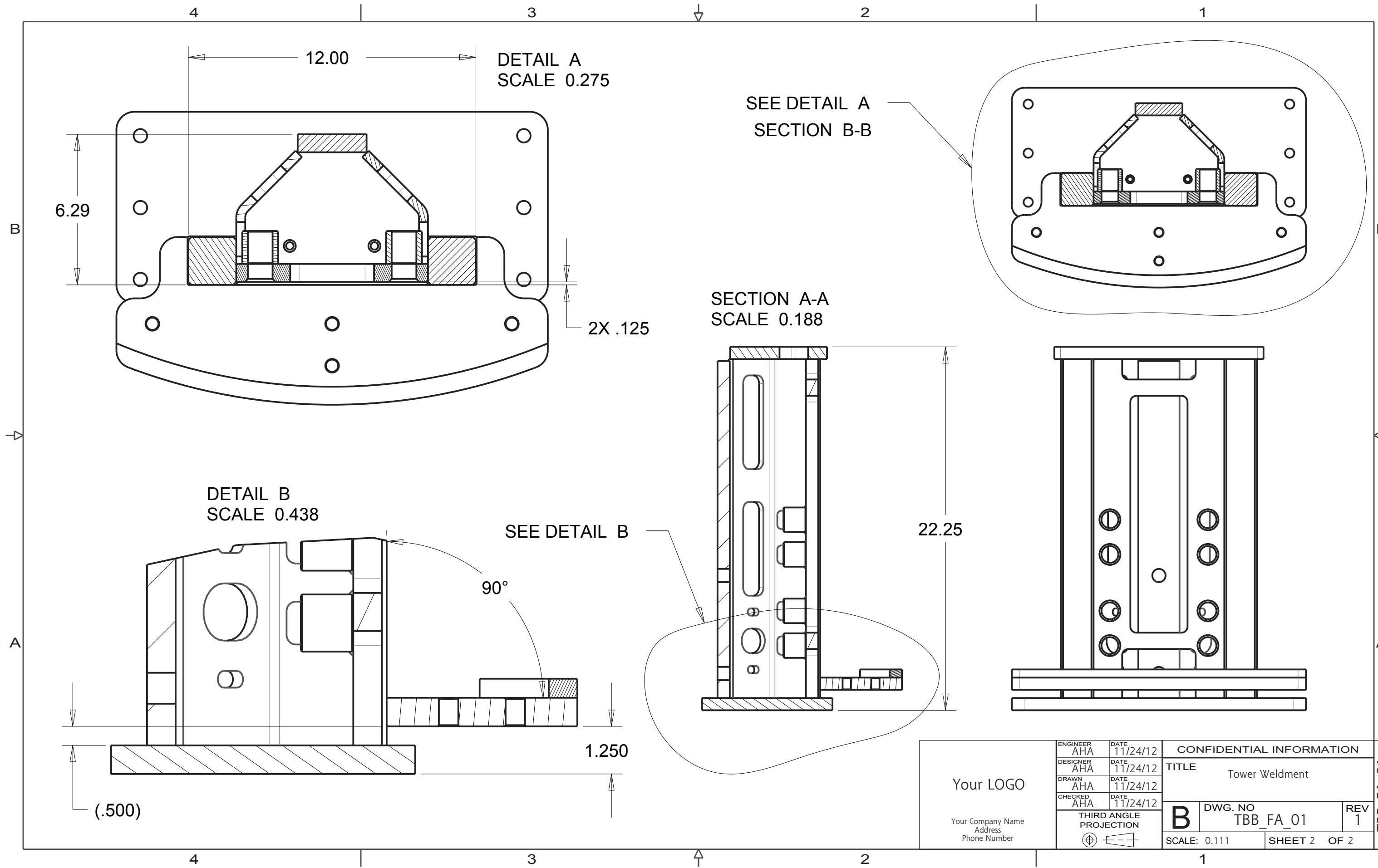

Your LOGO Your Company Name Address Phone Number	ENGINEER AHA	DATE 11/24/12	CONFIDENTIAL INFORMATION	
	DESIGNER AHA	DATE 11/24/12	TITLE Tower Weldment	
	DRAWN AHA	DATE 11/24/12	B	DWG. NO TBB_FA_01
	CHECKED AHA	DATE 11/24/12		REV 1
THIRD ANGLE PROJECTION		SCALE: 0.111		SHEET 2 OF 2

TBB_FA_01